

# Loop calibration and maintenance

## Application Note

### Introduction

Process instrumentation requires periodic calibration and maintenance to ensure that it is operating correctly. This application note contains information to help guide technicians through some of the more common loop calibration tasks using Fluke tools.

Fluke loop calibrators are ideal for a wide variety of calibration applications. They include:

- Fluke 707 Loop Calibrator
- Fluke 705 Loop Calibrator
- Fluke 715 Volt/mA Calibrator
- Fluke 787 and 789 ProcessMeter™ tools

A summary of the features of Fluke's loop calibrators and a glossary of terms are at the end of this application note.

### Field testing loop powered isolators

The loop-powered isolator and the two-wire isolating transmitter are two of the more prevalent devices in use in 4-20 mA control loops today (see Figure 1). The testing and troubleshooting procedures for each are different and need to be understood by the technicians performing operational checks on these units in the field.

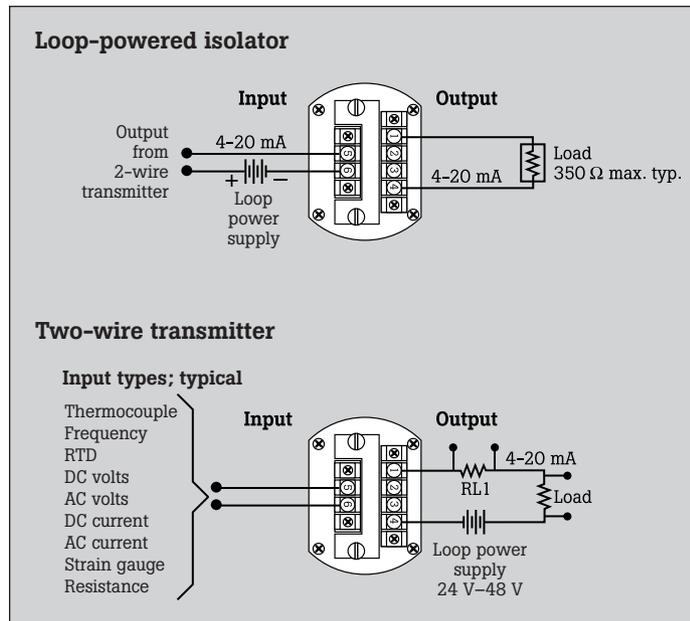

Figure 1

### Loop-powered isolators

The main purpose of a loop isolator is to eliminate ground loops in control systems while sending the control signal current to another part of the system. Loop-powered isolators, unlike two-wire transmitters, draw their operating power from the "input" side of the isolator (see Figure 1), which requires a pickup voltage from 5.5 V to 13.5 V depending on the manufacturer.

The output of the loop isolator is an electrically isolated mirror image of the input side current. The compliance voltage associated with the output is greatly reduced from that of the input side and ranges around 7.5 V. This produces a total loop loading capability of 350 Ω. This limited loop drive capability is the primary limitation of the loop isolator.

### Two-wire transmitters

Isolating two-wire transmitters provide the same isolating functionality as loop isolators with the added advantage that many provide signal conditioning for a variety of inputs such as thermocouple, frequency, dc current, RTD, strain gauge, and other process inputs. The power supplied to a two-wire transmitter is connected to the output side of the transmitter. The two-wire transmitter modulates the current from the power supply between 4-20 mA, proportional to the input. Typical power supplies for two-wire transmitters range from 24 V to 48 V. Power supplies of this size allow a significant loop load capability on the output.

### Field checking a loop-powered isolator

Fluke loop calibrators have a unique current simulation feature that, when connected to an external power source, allows you to precisely control current between 0 mA and 24 mA. When field checking a loop-powered isolator, the two-wire loop transmitter supplying signal current to the isolator for the loop may be removed and the calibrator connected in simulate mode to control loop current (Figure 2).

### Connecting the Fluke loop calibrator

In this example, we will use the Fluke 789 ProcessMeter. Although the operating controls vary, this application can also be performed using the Fluke 707, 715, and 705 loop calibrators.

1. Disconnect the main loop transmitter and connect the Fluke 789 to the loop with the test leads plugged into the center or "Simulate" terminals of the calibrator (see Figure 2).
2. Set the 789 rotary switch to the mA output mode. Set the Fluke 789 to the 4-20 mA output mode. Make connection for simulate mA. The 789 is now outputting a precise 4 mA and is providing operating power to the input of the loop-powered isolator.
3. Place a Fluke 187 or equivalent multimeter (1  $\mu$ A resolution is ideal; 10  $\mu$ A is acceptable), set in the mA measurement mode, on the output side of the isolator to monitor output current (see Figure 2).
4. Adjust the zero control on the isolator for a reading of 4.000 mA on the output meter (Fluke 187).
5. Step the input current to 20 mA using the % step button ▲ on the Fluke 789 (25 % or 4 mA increase) and adjust the span control on the isolator to read 20.000 mA on the output meter connected to the isolator.

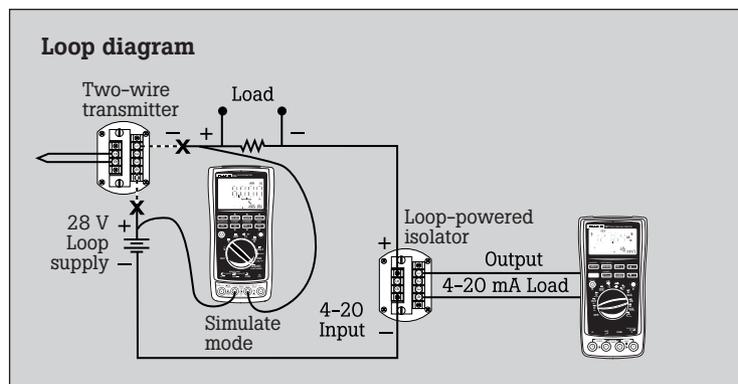

Figure 2

6. Step input current down to 4 mA using the ▼ button (25 % or 4 mA decrease) and check for a zero shift, adjust if necessary.
7. At this point, basic zero and span adjustments are complete.

### Check linearity

Fluke loop calibrators can easily check the linearity of your loop isolator using the % step buttons ▲ and ▼. Pushing these buttons when in the output mode increases or decreases the output current in 25 % steps. In the 4-20 mA current mode these intermediate steps are at 8 mA (25 %), 12 mA (50 %), and 16 mA (75 %). To check linearity of the isolator, push the associated % step buttons up and down and confirm that the digital multimeter (DMM) is reading the same value as is shown on the loop calibrator display. A variation from expected values should be compared to the linearity limits stated by the manufacturer of the loop-powered isolator.

### Testing valve positioners

Electronic valve positioners should receive periodic in-field calibrations as part of preventive maintenance programs. Fluke loop calibrators are the ideal test tools for these checks. Valve positioners vary in design and valve type and should be calibrated using specific instructions from the individual manufacturer.

Quick operational checks can be performed using a field calibrator as a signal source while observing the valve stem position, mechanical position indicators, or flow indicators as input changes are made. Fluke loop calibrators provide a convenient source for simulating the controller output to a valve positioner.

The following example shows a general method for an in-field operational check of a valve fitted with an electronic valve positioner. These methods may be adapted to various types of valves, however, manufacturer's specific instructions should always be consulted for proper and appropriate techniques. In the following example, valve operation and movement is checked either by feel or by observing valve stem movement.

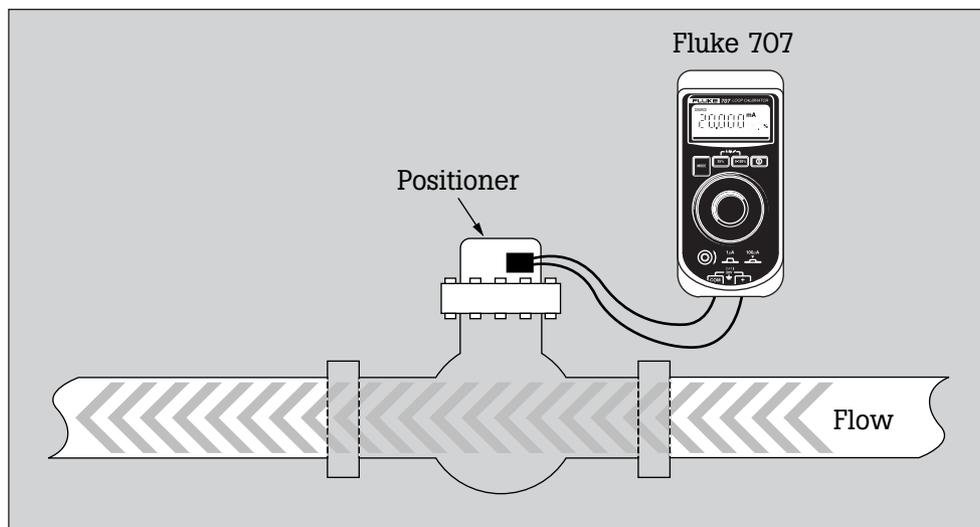

Figure 3

**Step 1: Basic set-up. Setting the Fluke 707 loop calibrator current output**

Place the calibrator in the 4–20 mA output current mode. Connect the 707 to the input terminals of the valve positioner (see Figure 3).

**Step 2: Zero adjustment**

Set the 707 to an output of 4 mA and allow some time for valve stem movement to stabilize. Quickly decrease the current from 4 mA to 3.9 mA by depressing and turning the vernier knob in a counter-clockwise direction. You can operate the 707 with one hand while feeling the valve stem with your free hand to check for any sign of movement. Adjust for zero movement between these two current settings by using the zero adjustment on the positioner.

Increase and decrease current from 4 mA to 4.1 mA using the vernier knob in the depressed position. Ensure that the valve stem just begins movement above the 4.1 mA setting and is fully closed at 4 mA.

**Step 3: Span (full open) position check**

Using the 25 % button, step the calibrator output value to 20 mA and allow the valve to stabilize. Step the input to 20.1 mA using the vernier knob in the depressed position turning clockwise while watching or feeling for movement of the valve stem. Minimize this movement using the span adjustment on the valve positioner.

Using the vernier knob in the depressed position, adjust current up and down between 20.10 mA and 19.9 mA. There should be no movement of the valve stem above 20 mA and a slight movement below 20 mA.

**Step 4: Check zero and span again**

Many positioners have interactive zero and span controls. This step will help ensure proper valve position adjustment.

Repeat Step 2 and Step 3.

**Step 5: Linearity check**

For valves with linear action, linearity can be checked by setting the 707 to 4 mA and stepping current to 12 mA (50 %) while observing valve travel. If your valve is of a non-linear type, refer to the valve manual for proper operational checks.

**Step 6: Stroking the valve**

Checking for smooth valve operation is easy to accomplish using the slow ramp function of the 707.

- Set the calibrator to **mA source mode** and select the slow ramp function (Λ) by depressing the 25 % and 0–100 % buttons simultaneously.
- Allow the calibrator to ramp through several cycles while watching or feeling for any abnormal operation of the valve, such as sticking in one position momentarily or erratic movement.

## Calibrating voltage input signal conditioners

Fluke loop calibrators are ideal for calibrating many 4–20 mA signal conditioners using their precision current sourcing and simulation capabilities. However, there are many signal conditioners that require a precision voltage source for proper calibration. Using a simple precision resistor and standard connector, Fluke loop calibrators can field calibrate many standard and non-standard voltage input signal conditioners. This approach works well for the 705, 707, 787 and 789 loop calibration tools (this is not necessary with the 715 loop calibrator as it has a precision direct voltage output).

Voltage input signal conditioners come in many varieties. The most common are 0–10 V, 0–5 V and 1–5 V input levels. Typical outputs of these devices are an isolated or non-isolated 0–10 V or 4–20 mA. Resistors with values of 250 Ω to 500 Ω are common loop load resistors and provide voltage input levels as a function of the loop current (see Figure 4).

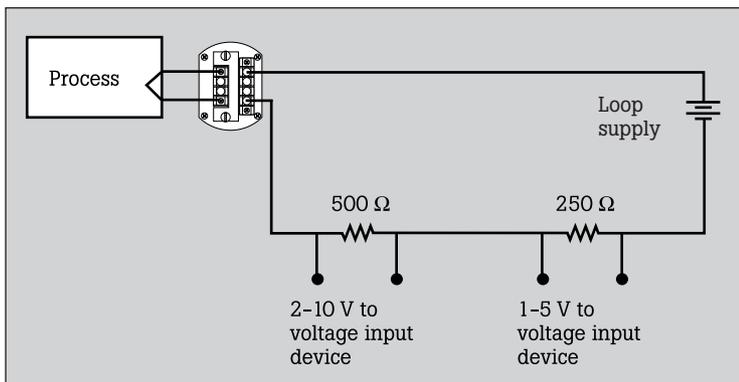

Figure 4

Resistor value	Sourced application	Generated current value	Fluke loop voltage	Calibrator
10 Ω	mV transducer	0–20.000 mA	0–200.00 mV	707, 705, 787, 789
250 Ω	0–5 V Source	0–20.000 mA	0–5.000 V	705, 707
1000 Ω	0–10 V Source	0–10.000 mA	0–10.000 V	705, 707, 787, 789

Note: Input impedance of the device under test should be  $\geq 1 \text{ M}\Omega$

Table 1. Values of precision resistors to accommodate a variety of voltage calibrations

### Using Fluke loop calibrators as a voltage source

A precision shunt resistor may be used to derive voltages for calibration using the calibrator’s current source mode. Using this system, Fluke loop calibrators are capable of generating voltages for devices with input spans as low as 10 mV to as high as 24 V. Table 1 gives values of precision resistors to accommodate a variety of voltage calibrations and the Fluke calibrator ideal for each application.

### Constructing a precision load resistor assembly

A simple precision current shunt can be constructed using a precision RN60, 1 W resistor, (see table for the correct value), a dual banana jack connector and some test leads with alligator clips (see Figure 5). The RN60 class resistor is available from many commercial sources. Construct the assembly as shown in Figure 5. This precision resistor assembly, coupled with the precision current sourcing capabilities of Fluke loop calibrators, generates precision voltages to cover 1–5 V or 2–10 V applications. The 1,000 Ω assembly has an advantage in that it allows a direct one-to-one display correlation to voltage when sourcing current from the Fluke loop calibrator during calibration (1 mA = 1 V). The following example will utilize a 250 Ω to take advantage of the 0–100 % and 25 % buttons on the Fluke 707 (25 % or 4 mA = 1 V).

#### Constructing a precision current shunt

##### Parts required:

1. Resistor: 1000 Ω  
Type: RN60 (50 ppm @ 70 °C) 1 W
2. 36" test leads with alligator clips
3. Connector: Dual banana plug 2/screw terminals

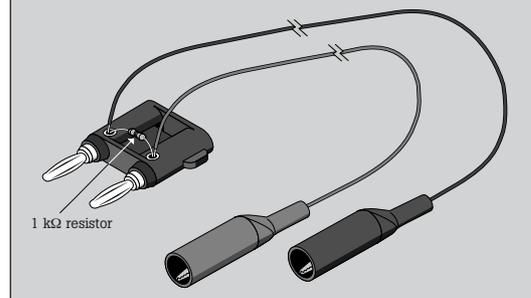

Figure 5

### Calibrating the signal conditioner

The following is a procedure for calibrating a 1-5 V input, 4-20 mA output signal conditioner using the precision current shunt constructed in Figure 5.

#### Step 1: Setting the Fluke 707 to source 4-20 mA

1. With the shunt assembly in the "source" jacks, power the 707 on.
2. Check the display. If the display does not read 4 mA, turn the 707 off and on again while holding the mode button for two seconds. The display should now read 4.000 mA.

#### Step 2: Calibrating

1. Place a precision multimeter, such as the Fluke 187 DMM, set to dc current mode, in series with the output of the signal conditioner as shown in Figure 6.
2. Connect the test leads from the precision shunt assembly to the signal conditioner input terminals, observing proper polarity.
3. With the 707 set in the mA source mode, the display should read 4 mA (1.00 V across the shunt).
4. Adjust the zero control on the signal conditioner for an indication of 4 mA on the DMM.
5. Press the 0-100 % button on the 707 until the display reads 20 mA. Then adjust the span adjustment on the signal conditioner until the display on the DMM reads 20 mA.
6. Push the 0-100 % button and the 707 should read 4. Verify the meter connected to the output signal conditioner reads 4 mA.<sup>1</sup>
7. Calibration is now complete.

Note: Many manufacturers specify a warm-up time prior to beginning calibration.

<sup>1</sup>If your output meter displayed a value higher or lower than 4 mA, consult the "Making fine adjustments" section on this page.

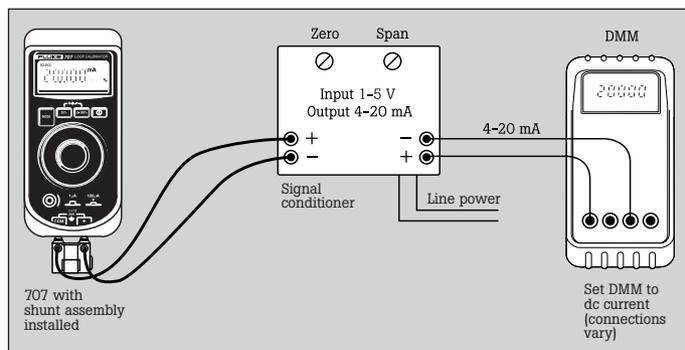

Figure 6

#### Step 3: Checking linearity

Once zero and span controls have been properly set, signal conditioner linearity may be verified using the following procedure. This procedure will check zero, 25 %, 50 %, 75 % and span settings for signal conditioner linearity.

1. With the precision resistor assembly in place, adjust the source current of the Fluke loop calibrator to 4 mA (1.0 V) using the 25 % button. The DMM displays 4 mA.
2. Using the 25 % button, step the source current to 25 %, 50 %, 75 % and 100 % and note the corresponding values. Table 2 shows the correct values of output for a linear signal conditioner. (If values differ from that shown in Table 2 by more than the linearity specification of the signal conditioner, contact the signal conditioner manufacturer or replace the device.)

#### Making fine adjustments

Many signal conditioners with 0-20 mA and 4-20 mA outputs are notorious for zero and span control interaction. If, when checking linearity in the calibration section, your output meter displayed a value higher or lower than 4 mA, perform the following steps to affect the required 4 and 20 mA display on the output meter.

1. Note the value above or below 4 mA that was displayed on the output meter when you returned to a source value of 4 mA on the 707. Adjust the zero control on the signal conditioner so the value of the output meter shows one-half the difference of the remaining mA value to 4 mA.

**Example:** If your display reading at zero input in Step 7 was 3.50 mA adjust the output (with 4 mA source current) to display a reading of 3.75 mA, which is one-half the delta toward the desired value of 4 mA; e.g.,  $4.00 - 3.50 = 0.50$ ;  $0.05 / 2 + 3.50 = 3.75$ , or one-half the difference between the reading and the desired value.

Fluke display reading	% Input	Input voltage	Output current
4.000	0	1.000 V	4.000 mA
8.000	25	2.000 V	8.000 mA
12.000	50	3.000 V	12.000 mA
16.000	75	4.000 V	16.000 mA
20.000	100	5.000 V	20.000 mA

Table 2. Correct value of output for a linear signal conditioner

- Set the source current of the 707 to 20 mA using the 0-100 % button. Note the "output" meter display reading. Adjust the span control of the signal conditioner one-half the delta from 20 mA.

**Example:** If the output display reads 21 mA, adjust the span control to 20.5 mA (one-half the delta to the required value of 20 mA).

- Repeat this "one-half step" process until the required output is obtained. There are signal conditioners that have non-interactive controls that do not require this procedure.

### Verifying process scaled, indicators

Scaled process indicators are used to provide information about a process either locally or to a control room located a distance away. These indicators typically take a mA measurement in series with the 4-20 mA loop signal or measure a 1 V to 5 V drop across a 250 ohm resistor in series with the 4-20 mA signal (a 4-20 mA signal through a 250 ohm resistor produces a 1 V to 5 V drop).

For indicators with a mA input, the direct mA current output of a 705, 707, 715, 787 or 789 can be applied directly to the input of the indicator. For voltage input indicators, a 715 is ideal with its direct voltage output. Or use a resistor across the output of a 705, 707, 787 or 789 as described previously ("Using Fluke loop calibrators as a voltage source").

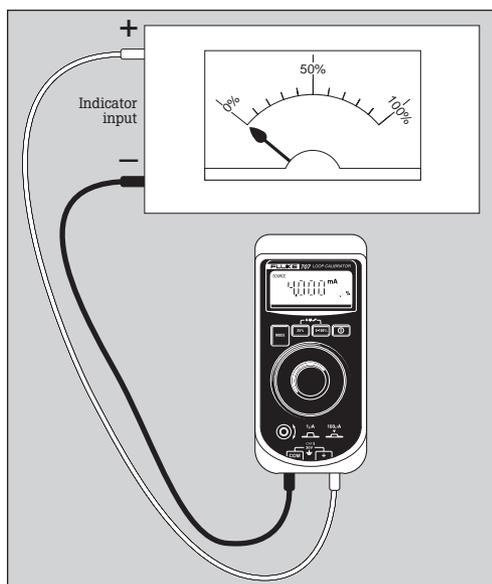

Figure 7

This example will show how to use the 707 to verify a mA input indicator. Make connections as shown in Figure 7.

- Power the 707 up; the default output should be 4 mA. Note the indication, (digital or analog) which should be approximately 0 %.
- Depress the 0-100 % button on the 707; it is now in the span check mode and is outputting 20 mA. Note the indication (approximately 100 %).
- If testing the linearity is necessary, use the 25 % button to step the mA output in 4 mA steps and record the indications.
- To calculate the errors in percent, use the formula:

**Nominal - actual/span x 100**  
 Nominal is the ideal value, actual is the recorded measurement and span is 16 (4-20 mA = a 16 mA span).

**Example:** If the indication with 0 % applied is 1 %, calculate error as such:  $0 - 1/16 = .0625 \times 100 = 6.25 \%$  error. Calculate error based on the recorded indications and compare to the tolerances for the indicator. If any of the calculated errors are too

large, adjustment may be necessary. Normally, there are at least two adjustments for analog indicators: zero and span. The zero adjustment is typically on the faceplate of the indicator.

- With an output of 4 mA from the 707 adjust the zero indication. Span adjustment is either a hard adjustment or accomplished by bending a linkage on the meter movement. Refer to the manufacturer's procedure for this adjustment.
- Apply a 20 mA signal to the indicator and make the adjustment as specified. Once the adjustment is completed, re-verify the indicator and confirm the adjustments had the desired effect. If the indicator still fails the test, it will either need to be readjusted until a satisfactory result is attained, or replaced.

### Voltage input indicators

The procedure for using the 707 to verify voltage input indicators is almost identical to the procedure outlined. The primary difference is the addition of the precision 250 ohm adapter.

## Fluke Loop Calibrator Considerations and Selection

Fluke loop calibration tools have a variety of different performance features and capabilities that differentiate the models. The charts below will help you determine which model best fits your needs:

	<b>707 Loop Calibrator</b>	<b>715 Volt/mA Calibrator</b>	<b>705 Loop Calibrator</b>	<b>787 and 789 ProcessMeter™</b>
<b>Function</b>	<ul style="list-style-type: none"> <li>• One-handed quick click operation</li> <li>• Simultaneous mA and % of span display</li> <li>• Push button 25 % steps</li> <li>• 0.015 % accuracy and 1 microamp resolution in any current mode</li> </ul>	<ul style="list-style-type: none"> <li>• Source or simulate 24 mA loop current</li> <li>• Source voltage to 100 mV or 10 V</li> <li>• Measure voltage output process signals</li> </ul>	<ul style="list-style-type: none"> <li>• Simultaneous mA and % of span display</li> <li>• Accuracy and resolution</li> <li>• Span check</li> <li>• Auto ramping and stepping</li> </ul>	<ul style="list-style-type: none"> <li>• Two instruments in one: -Professional DMM -Loop calibrator</li> <li>• Precise control of loop current</li> <li>• Auto ramping &amp; stepping</li> <li>• High level of safety (Cat III)</li> </ul>
<b>Measure</b>				
DMM capabilities				•
V dc	28 V	10 V	28 V	1000 V
V ac (true-rms)				1000 V
Ω				40 MΩ
A dc	24 mA	24 mA	24 mA	30 mA, 1 A
A ac				1 A
Frequency Hz/CPM				20 kHz
mA accuracy	0.015 %	0.015 %	0.020 %	0.05 %
Span check	•		•	
<b>Source/Simulate</b>				
V dc		10 V		
Source voltage with μV resolution (1-10 Volts)		•		
mA dc/% scale	24 mA	24 mA	24 mA	24 mA
mA source: auto step, auto ramp	•		•	•
<b>Record</b>				
Min/Max				•
Hold				•
<b>Features</b>				
24 V loop supply	•	•	•	(789)
Drive capability	24 V compliance	24 V compliance	24 V compliance	787 12 V - 789 24 V
Warranty	3 year	3 year	3 year	3 year
IEC 61010 category/ max voltage	30 V	30 V	30 V	1000 V, CAT III

<b>Accessories</b>	<b>707 Loop Calibrator</b>	<b>715 Volt/mA Calibrator</b>	<b>705 Loop Calibrator</b>	<b>787 and 789 ProcessMeter™</b>
787CAL Calibration Kit				•
80T-IR Infrared Probe		•		•
80TK Thermocouple		•		•
80T-150U Temperature Probe		•		•
TL20/22/24/26/28 Lead Sets	•	•	•	•
TL70A/TL75/Y8140A Lead Sets	•	•	•	•
AC20/AC80 Clips	•	•	•	•
TP20 Industrial Test Probes	•	•	•	•
80i-400 AC Current Clamp				•
i410 AC/DC Current Clamp		2		1
i1010 AC/DC Current Clamp		2		1
C10 Holster, C12A Case	•		•	
C25/C28/V90/C100/C800 Cases		•		•
C510 Leather Case		•		•
80K-6/80K-40 High Voltage Probe				•
83RF/85RF High Frequency Probes				•
PV350 Pressure Vacuum Module		•		•
Fiber Optic Meter FOM		•		•

<sup>1</sup>20 amps ac minimum    <sup>2</sup>dc current only

## Glossary of terms

<b>4-20 mA loop</b>	A 4-20 mA signal that is representative of a process variable or a control signal that controls a process variable.
<b>Compliance voltage</b>	The voltage a current source develops when attempting to drive a mA signal through a resistive load.
<b>DMM</b>	Digital multimeter.
<b>Electronic valve positioners</b>	Devices that can control the flow in a process with input from a mA or digital control signal.
<b>Ground loop</b>	A difference in potential (voltage) between (2) signal grounds.
<b>Linearity</b>	The closeness of a calibration curve to a specified straight line. Linearity is expressed as the maximum deviation of any calibration point from a specified straight line.
<b>Loop-powered isolator</b>	A device that produces an electrically isolated mirror image of the input side 4-20 mA current.
<b>mA</b>	Milliamp; a unit of electric current equal to one thousandth of an ampere.
<b>Precision current shunt</b>	A conductor joining two points in a circuit to form a parallel circuit, through which a precision voltage can be measured or derived.
<b>RTD</b>	Resistance temperature device, a temperature measurement sensor that has predictable changes in resistance with a change in temperature.
<b>Signal conditioner</b>	A circuit to modulate a signal so as to make it intelligible to, or compatible with, another device, including such manipulation as pulse shaping, pulse clipping, compensating, digitizing, and linearizing.
<b>Strain gauge</b>	A measuring element for converting force, pressure, tension, etc., into an electrical signal.
<b>Thermocouple</b>	A junction of dissimilar metals that generates a small voltage correlated to the temperature of the junction.
<b>µA or uA</b>	Microamp; a unit of electric current equal to one millionth of an ampere.
<b>Vernier</b>	A small, movable, graduated scale running parallel to the fixed graduated scale and used for measuring a fractional part of one of the divisions of the fixed scale.

**Fluke.** *Keeping your world up and running.*

**Fluke Corporation**  
PO Box 9090, Everett, WA USA 98206

Fluke Europe B.V.  
PO Box 1186, 5602 BD  
Eindhoven, The Netherlands

For more information call:  
In the U.S.A. (800) 443-5853 or  
Fax (425) 446-5116  
In Europe/M-East/Africa (31 40) 2 675 200 or  
Fax (31 40) 2 675 222  
Canada (800)-36-FLUKE or  
Fax (905) 890-6866  
Other countries (425) 446-5500 or  
Fax (425) 446-5116  
Web access: <http://www.fluke.com>

©2003 Fluke Corporation. All rights reserved.  
Trademarks are the property of their respective owners.  
Printed in the Netherlands 4/2003 Pub ID 10437-eng  
Rev. 02