

Technical/Application Article 12

Version 1.0 20 April 2017 WRH/FD

Continuous Benzene-Specific Monitoring Using the Titan

Introduction

Benzene monitoring is important because it is by far the most toxic component of many fuels, and it is a known human carcinogen. The Titan is the world's first industrial hygiene monitor that is both specific to benzene and performs continuous measurements. It is a fixed-mounted monitor designed to isolate benzene from hydrocarbons found in refineries, fuel transport operations, and similar applications, such as coke oven emissions during steel production. The Titan works using an internal separator with one- to two-minute cycle time, and requires no consumable reagents or gases, other than electrical power. This Article describes the benzene sensitivity and operating limits where interferences might occur.



Titan Operation

With IP65 ingress protection, the Titan can be installed outdoors and the internal pump can draw sample gas from up to 10 meters away. The pump runs at 200 cc/min for 38 seconds out of every minute for an effective flowrate of 127 cc/min. This bulk sample air flow is shown in Figure 1 by the bold arrows leading in and out of the large pump. During sample injection (Fig. 1a), the large pump turns off and the small pump draws a small sample onto the AirSep filter. During benzene separation and analysis (Fig. 1b), the valves switch and both pumps are on. The small pump draws air through an activated carbon filter (GAC) to provide purified purge gas to the AirSep filter. The isolated benzene is then measured by PID. The bulk air flow (large pump) continues during this analysis time so as to always maintain a fresh sample for the next injection, which is especially important for remote sampling.

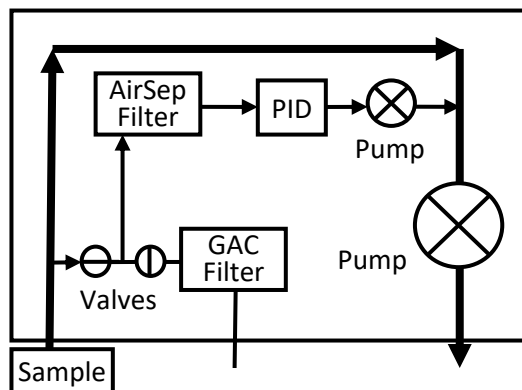

Figure 1a. Flow schematic during sample injection.

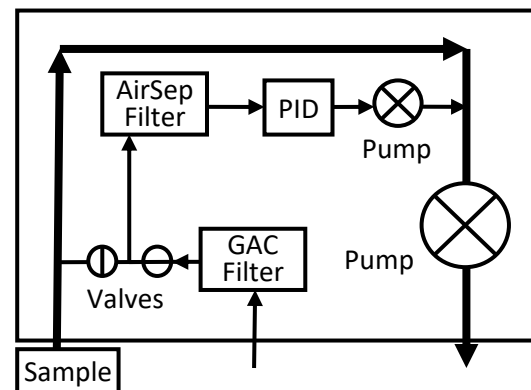

Figure 1b. Flow schematic during sample analysis.

Benzene Response Linearity

Figures 2a and 2b show that benzene response on the Titan is linear in both the low concentration range (to less than 1 ppm) and the full range up to 20 ppm. The detection limit is 0.1 ppm.

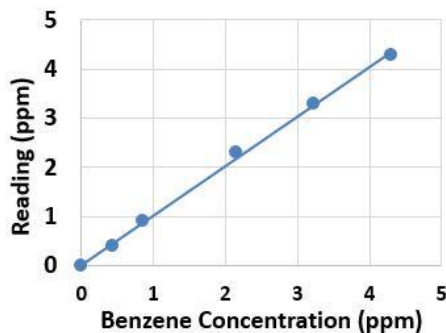

Figure 2a. Benzene response linearity - low range.

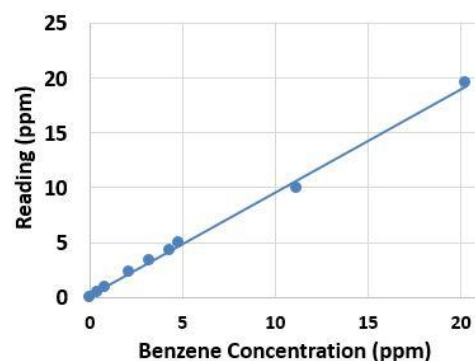

Figure 2b. Benzene response linearity - full range.

Benzene Selectivity

The left side of Table 1 shows the response of the Titan to various compounds tested alone. There is no response to aromatic and aliphatic hydrocarbons commonly found in liquid fuels (gasoline, petrol, diesel, etc.), liquid petroleum gas (LPG) or natural gas (mostly methane). The right side of the table gives the readings for mixtures of benzene with the test compound. At the concentrations listed, these compounds did not have any significant effect on the benzene readings in the mixtures. Figure 3 demonstrates that, collectively, the myriad of components in a typical gasoline mixture do not affect the response of the benzene naturally present in the gasoline itself. Some oxygenated and chlorinated solvents like isopropanol and trichloroethylene do give some interference and therefore such solvents should not be used near the Titan installation.

Table 1. Benzene Interference Tests on the Titan.

Compound Alone	Test Conc. (ppm)	Reading	Compound/Benzene Mix Conc. (ppm)	Reading
Toluene	100	0	100 + 5	5
Xylene	100	0	100 + 5	5
Xylene	10*	0	10 + 2	1.8
Ethylbenzene	100	0	100 + 5	5
Isooctane	30	0	40 + 2	1.8
Undecane	100	0	100 + 5	5
n-Hexane	100*	0	100 + 2	1.7
Cyclohexane	100	0	100 + 5	5
Propane	5000*	0	5000 + 10	9.3
Methane	Vol %*	0	-	-
Isobutylene	100	0	-	-
Gasoline (Petrol)	-	-	100 [†]	1.1 [†]
Naphtha, light	100	0	100 + 5	5
Naphtha, wide cut	100	0	100 + 5	5
Mixture of toluene, xylene, n-hexane, cyclohexane and ethanol	10 ppm each	0	10 each + 1	1
CO	100	0	-	-
Methanol	50	0	-	-
Ethanol	50	2	-	-
Isopropanol	11	3	-	-
Ethyl Acetate	50	3	-	-
Acetone	50	11	-	-
Trichloroethylene	50	>20	-	-

[†] Benzene is present in refined fuels and thus gives a response. See Fig.3.

* Higher concentrations may cause decreased benzene response. For methane, this occurs above 1% vol.

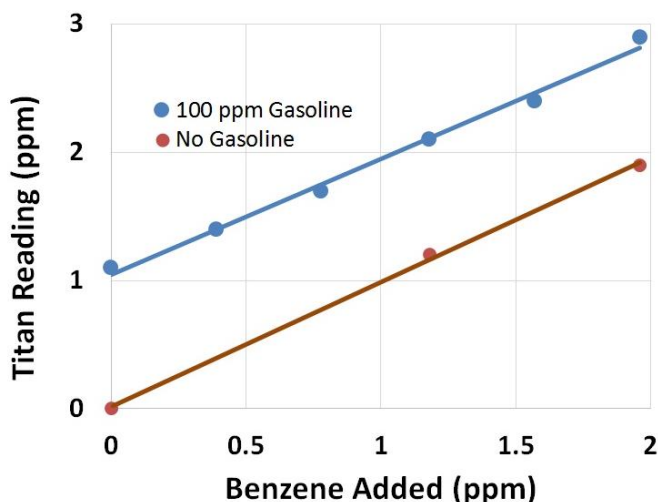

Figure 3. Titan response with added benzene in the absence and presence of 100 ppm gasoline. The graph shows that, as received, the gasoline sample contained 1.1% benzene without any addition. The fact that both curves have the same slope of 1 means that the other gasoline components have no effect on the benzene response. In other words, the amount the reading increases equals the amount of benzene added, and thus there is no interference.

Importance of Continuous Measurements

Figure 4 demonstrates the importance of continuous monitoring. In a field study we compared the response of the Titan to an on-line gas chromatograph (GC). The Titan makes a measurement every 1-2 minutes, whereas the GC has a turnaround time of one hour. In this example, significant amounts of benzene were present between 30 and 70 minutes and were clearly delineated by the Titan, but almost entirely missed by the GC, because it only sampled once just before this time period. Therefore the Titan provides a better warning of potentially hazardous atmospheres than an on-line GC.

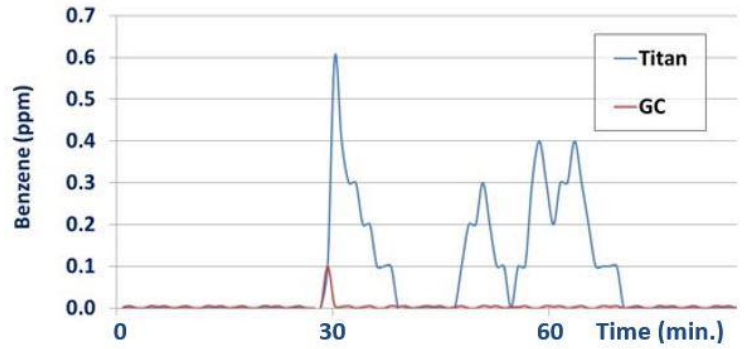

Figure 4. Titan's continuous readings record benzene emissions completely missed by an on-line GC.

For more information contact Ion Science:
E-mail: info@ionscience.com
www.ionscience.com